

NP12-50Ah 12V50Ah

● **Specifications**

Nominal Voltage		12V
Rated capacity (10 hour rate)		50Ah
Dimensions	Length	230±2mm(9.06inch)
	Width	138±2mm(5.43inch)
	Height	211±2mm(8.31inch)
	Total Height	215±2mm(8.46inch)
Approx. Weight		15.9kg(35.05lbs)±3%



● **Outer dimensions (mm)**

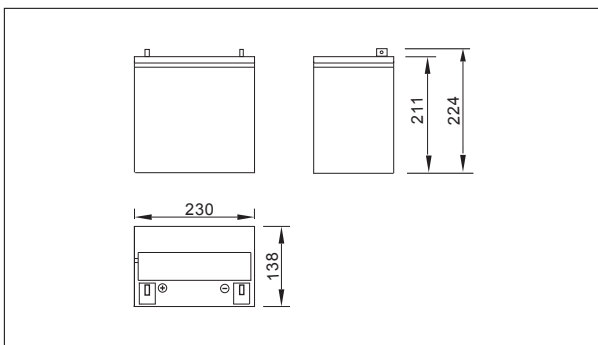

● **Terminal Type (mm)**

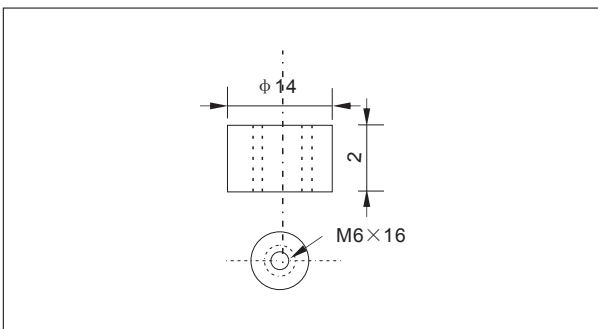

● **Construction**

Component	Positive plate	Negative plate	Container	Cover	Separator	Electrolyte	Safety valve	Terminal
Raw material	Lead dioxide	Lead	ABS	ABS	AGM	Sulfuric acid	Rubber	Copper

● **Constant Current Discharge Characteristics Unit:A(25°C,77°F)**

F.V/Time	10min	15min	30min	60min	2h	3h	4h	5h	8h	10h	20h
9.60V	109	84.0	50.3	30.9	18.3	13.2	10.5	8.98	6.17	5.09	2.70
9.90V	106	82.0	49.2	30.4	18.2	13.1	10.4	8.92	6.13	5.08	2.69
10.2V	101	79.0	47.7	29.7	18.0	13.0	10.4	8.86	6.09	5.07	2.68
10.5V	97.0	76.3	46.6	28.7	17.7	12.9	10.3	8.80	6.05	5.04	2.67
10.8V	91.6	72.2	44.9	27.8	17.3	12.5	9.99	8.54	5.87	5.00	2.65

● **Constant Power Discharge Characteristics Unit:W(25°C,77°F)**

F.V/Time	10min	15min	30min	60min	2h	3h	4h	5h	8h	10h	20h
9.60V	1177	922	564	352	212	155	124	106	73.3	60.8	32.4
9.90V	1142	900	553	347	210	154	123	105	72.9	60.7	32.3
10.2V	1095	867	536	338	208	153	122	105	72.4	60.5	32.2
10.5V	1048	837	523	328	205	152	121	104	71.9	60.1	32.0
10.8V	989	793	503	317	200	147	117	101	69.7	59.7	31.8

Note: The above characteristics data can be obtained within three charge or discharge cycles.

● **Characteristics**

Capacity (25°C)	10HR(10.8V)	50Ah
	3HR(10.8V)	37.5Ah
	1HR(10.5V)	27.5Ah
Terminal type		T14
Internal resistance (Fully charged,25°C)		Approx.7.5m Ω
Capacity affected by temperature (10HR)	40°C	102%
	25°C	100%
	0°C	85%
	-15°C	65%
Self-discharge (25°C)	3month	Remaining Capacity:91%
	6month	Remaining Capacity:82%
	12month	Remaining Capacity:65%
Nominal operating temperature		25°C ±3°C(77°F ±5°F)
Operating temperature range	Discharge	-15°C~50°C(5°F~122°F)
	Charge	-10°C~50°C(14°F~122°F)
	Storage	-20°C~50°C(-4°F~122°F)
Float charging voltage(25°C)		13.50 to 13.80V Temperature compensation: -18mV/°C
Cyclic charging voltage(25°C)		14.50 to 15.00V Temperature compensation: -30mV/°C
Maximum charging current		15A
Terminal material		Copper
Maximum discharge current		500A(5 sec.)
Designed floating life(20°C)		10years

NP12-50Ah 12V50Ah

Discharge characteristics(25°C)

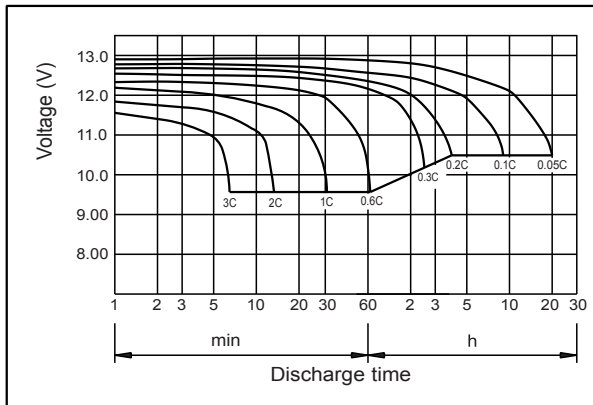

Charging characteristics (25°C)

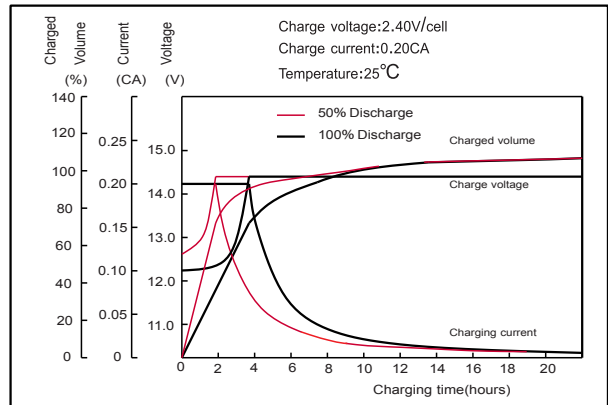

Temperature effects on Capacity

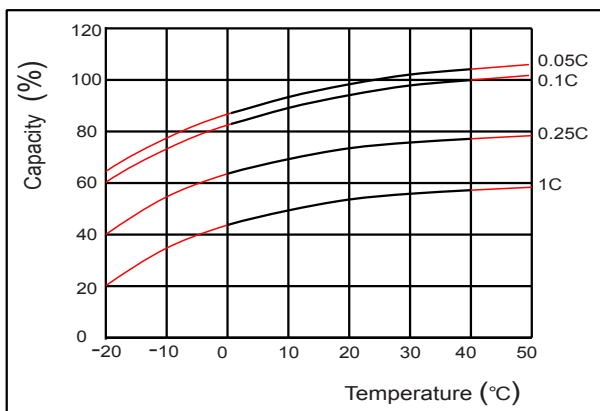

Self-discharge characteristics

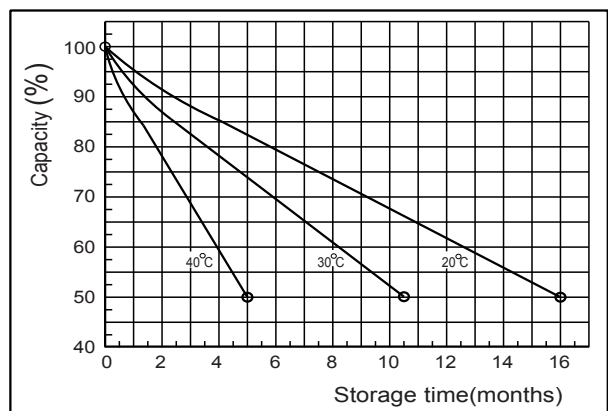

Floating life on Temperature

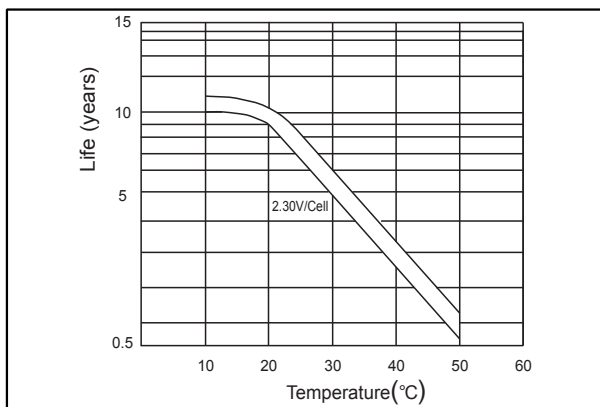

Cycle life on D.O.D (25°C)

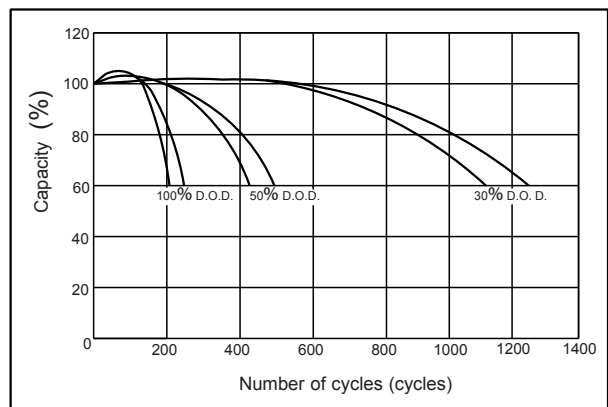

The relationship for OCV and Capacity (25°C)

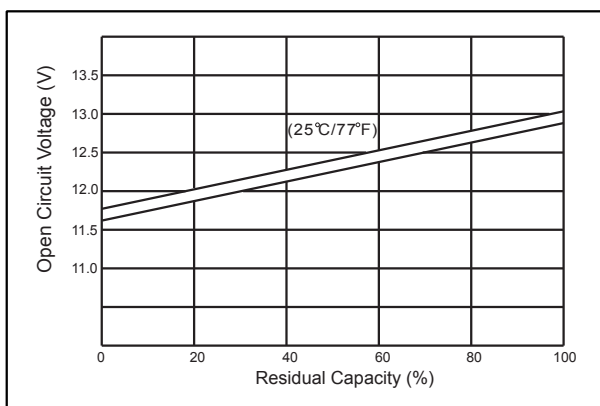

The relationship for Charging voltage and Temperature

